



**FIRST  
NATIONAL  
BATTERY**

THROUGH CARING WE LEAD™



**FIRST™  
NATIONAL  
BATTERY**

**INDUSTRIAL (PTY) LTD**

THROUGH CARING WE LEAD

# MINING AND MATERIALS HANDLING

**MOTIVE POWER BATTERIES  
INSTALLATION AND  
MAINTENANCE INSTRUCTIONS**



ISO 14001:2004  
ISO 9001: 2000  
ISO/TS 16949:2002

**SANS IEC 60254-1,2:1997**

# Fundamental Principles

A lead acid battery stores electrical power in chemical form, and consists of two or more cells. Each cell comprises two dissimilar compounds of lead, immersed in dilute sulphuric acid.

In its fully charged state, the active material of the positive plate is lead dioxide, and that of the negative plate, porous or spongy lead.

A lead acid battery is a “secondary battery” which means it can be discharged and recharged a number of times before reaching the end of its life. This is because the chemical reaction which takes place in a lead acid battery is reversible. (Primary batteries, such as zinc/manganese dioxide batteries widely used in torches, radios etc. cannot be recharged and have to be discarded once discharged).

When a cell is discharged, the sulphuric acid reacts with the active materials on the positive and negative plates. From the reaction on the spongy lead of the negative plate, electrons are liberated, whilst electrons are absorbed by the reaction on the lead dioxide on the positive plate. Consequently a current flows between the two plates.

Furthermore, in both reactions the active materials are gradually converted to lead sulphate, whilst the sulphuric acid is converted to water. As sulphuric acid is heavier than water, the specific gravity (S.G.) of the electrolyte drops during discharge, as the acid is being “used up”. In the process, the volume of the electrolyte decreases somewhat, with a resultant drop in the electrolyte level.

When recharged, the sulphate ions in the active materials recombine with the excess water in the electrolyte and convert back to sulphuric acid. As a result, the S.G. increases back to original top of charge levels. Simultaneously the lead sulphate converts back to lead dioxide on the positive, and spongy lead on the negative plate. Again, the volume of electrolyte increases, and the electrolyte level rises, as the cell is charged.

As the cell approaches its fully charged condition, the chemical conversion can no longer absorb all of the charging current. The surplus current results in the liberation of hydrogen from the negative plate, and oxygen from the positive plate. This process is commonly known as gassing and is the primary reason why these cells need regular topping up with water. Subject to the condition and age of the cell, gassing normally starts at approximately 2.38 volts.

Gassing helps to agitate the electrolyte in the cell, thereby mixing the heavy sulphuric acid with the water in the electrolyte. Specific gravity readings during charge should therefore always be taken at the end of charge to ensure proper readings. **Illustration 1:** While the electrolyte S.G. drops linearly with discharge, it increases meaningfully during recharge only once the gassing voltage is reached.

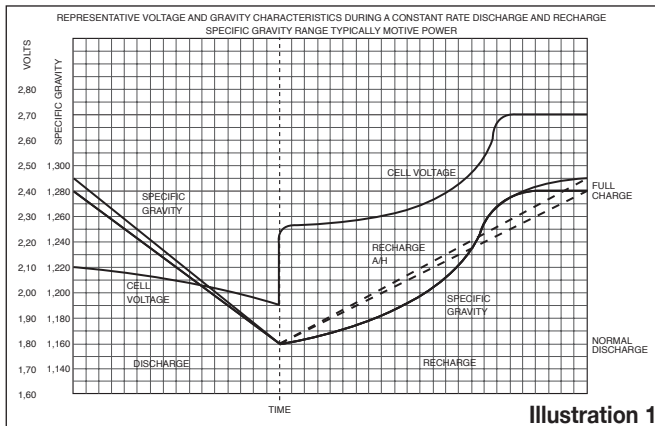
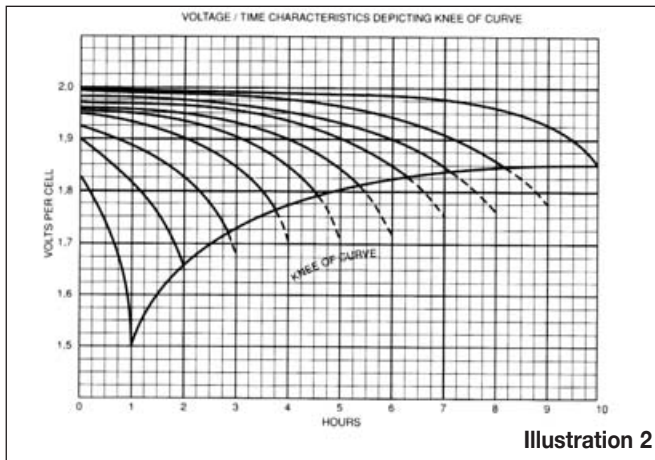

Illustration 1

Because of the linear change of electrolyte S.G. during discharge, S.G. is preferred over voltage as a measure of state of discharge. Temperature affects S.G. and S.G. readings taken should be adjusted to 25°C.

The open circuit voltage of a fully charged cell is approximately 2.13 volts. When on charge, the voltage will rise from approximately 2.15 volt to a final value approaching 2.70 volts, at a finishing current of 3% of the cell 5 hour capacity.

Cell capacity is dependent upon the discharge rate. Motive power batteries are rated at the 5 hour discharge rate. This means that a 500 ampere hour (Ah) battery can be discharged for 5 hours at 100 amperes to a minimum voltage of 1.7 volt per cell. Beyond this point, known as the knee of the voltage curve, the cell voltage will drop off rapidly. Refer to **illustration 2**. Higher or lower rates of discharge have lower and higher voltage cut off points respectively.



Battery life is dependent on many factors, of which temperature, quality of topping up water, depth of discharge, proper charging and regular maintenance are of major importance.

High cell temperatures reduce life dramatically. Unnecessarily high charge rates and high ambient temperatures are prime reasons for high cell temperatures.

Poor quality topping up water containing harmful substances will chemically reduce the ability of the cell to deliver to its rated capacity.

Over-discharging can result in bursting of the positive tubes and loss of active material.

Incomplete charging will lead to irreversible sulphation of cells, and out of step batteries. Overcharging will result in damage to the plates and high cell temperatures.

Regular and proper maintenance is important to identify and correct such problems before permanent harm is done to a battery. The following chapters serve as a guide to help users perform this maintenance.

# Preparing a Battery for Service

## UNPACKING

Keep the trays upright. If rope or chain slings are used, keep the slings vertical. At all times chains and other metal parts should be kept away from the top of the battery. Clean off the packing material from the cells and trays. Examine carefully to see if there has been any damage in transit.

Important: Any damage must be reported to the carrier and First National Battery must be notified that this has been done.



## CELL LIFTER (OPTIONAL)

To facilitate easy removal of cells from tanks, or shipping crates, this cell lifter is designed to ensure no damage occurs.

| Cell       | Cat No. |
|------------|---------|
| DIN 5 – 21 | R10     |
| BS 5 – 15  | R11     |
| BS 17 – 19 | R12     |

## PREPARING THE CELLS

- Open all vent filler plugs and examine the electrolyte levels in all cells.
- Record all specific gravities (25°C).
- Batteries can be put into service immediately, provided the specific gravities are above 1.240 (25°C) and electrolyte levels are correct. If the specific gravities are below 1.240 it is necessary to give the battery an equalizing charge.

If the battery is not required immediately for service, it should be given further equalizing charges at monthly intervals and the electrolyte levels should be adjusted by topping up with approved water.

## FITTING ON VEHICLES / MATERIALS HANDLING EQUIPMENT

Wipe the top of the battery to ensure that it is both clean and dry.

Ensure that connecting cables are well anchored and sufficiently long to prevent tension on battery terminals. Cells should be packed tightly together to prevent unnecessary movement and stress on connections.

## PHYSICAL REQUIREMENTS

The battery compartment must be ventilated but should protect the battery from water, oil, dirt and other foreign matter.

Drainage openings should be provided in the floor of the compartment. The battery should be installed in the compartment in accordance with the layout sketch or drawing supplied by the user or by First National Battery. It should fit the truck compartment firmly and evenly and should be blocked, not wedged, in such a way as to allow about 3 mm clearance on all sides to facilitate battery changes.

## **ELECTRICAL CONNECTIONS**

If a battery consists of two or more tanks, connect them in series, positive terminal to negative terminal.

To connect the complete battery to the charger, connect the positive terminal of the battery to the positive terminal of the charger and the negative terminal of battery to the negative terminal of the charger. If any connections on the battery itself are bolted together, ensure that they are clean.

No 'tappings' or connections should be made other than at the main terminals of the battery. Any lower voltage device should be supplied via a DC/DC convertor or from a separate source. Connecting any such device to an intermediate point of a battery will result in overworking one section of the battery and/or overcharging the remainder.

## **PROCEDURE FOR FITTING PERFECT SEAL BATTERY CONNECTORS**

### **Assembly of SMP / Euro-style Santoprene Connectors**

Fit Euro-style connector - see connector drawing 2517.02.2 and drawing 2530.01.2 for DIN and drawing 2518.02.2 for B.S. For assembly see drawing 2548.01.3.

**Note:** Check if ferrule of connector is dish shaped. If so, the concave side must face down - to be in contact with the post.

Ensure that M10 plastic head bolt (H52) has vibration resistant compound threads. Screw bolt down, loosely. Check and adjust connector position. While keeping the connector head in correct position by means of spanner R13 for 35 & 50mm<sup>2</sup> and spanner R14 for 70mm<sup>2</sup>, torque bolt to  $22 \pm 2$  Nm. A single hex socket must be used. Prevent the connector from rotating when tightening.

### **To disconnect the Connector**

Simply loosen plastic head bolt, using single head socket and wrench.

### **Assembly of OLD MMP Santoprene Connectors**

Lightly smear Petroleum Jelly or SWIFT 500H paste around sides of the pillar making sure there is a fillet of paste at the intersection of the cover and injection moulded polypropylene seal. Do not get Jelly / Paste on top surface of the threaded insert. Fit perfect seal santoprene connector. See Connector drawing no. 2174.01.1 and assembly drawing no. 2264.01.3.

**Note:** Check if ferrule of connector is dish shaped. If so, the concave must be to the bottom. If moulded incorrectly - do not use.

Put a drop of Loctite (Nutlock 243) on the thread of the M10 stainless cap screw. Screw the bolts on loosely. Check and adjust correct position of the screws. While keeping the connector head in correct position by means of a spanner (Drg 5501.01.3) the bolt is fixed with a torque wrench.

Adjust torque at  $34 \pm 2$  Nm. Prevent the connector rotating when tightening. Cover the top of screw, filling the connector head with Petroleum Jelly or Swift 500 H paste. Press the cap into the connector head and ensure that it is secure. Clean excess Jelly / Paste from the top of the connector and lid.

### **To disconnect the Connector**

For disconnection, the first step is to remove the cap by means of a lever or screwdriver. After re-connection, all lids have to be re-fitted. The connector is to be replaced, if damaged.

### **Assembly of OLD PVC Connectors**

Lightly smear Petroleum Jelly or SWIFT 500H paste around sides of the pillar making sure there is a fillet of paste at the intersection of the cover and injection moulded polypropylene seal. Do not get Jelly / Paste on top surface of the threaded insert. Position "o" ring (K25) over threaded insert and fit perfect seal connector.

**Note:** Check if ferrule of connector is dish shaped. If so, the concave must be to the bottom. If moulded incorrectly - do not use.

Put a drop of Loctite (Nutlock 243) on the thread of the M10 stainless cap screw. Screw the bolts on loosely. Check and adjust correct position of the screws. While keeping the connector head in correct position by means of a spanner (Drg 1318-01-30) the bolt is fixed with a torque wrench. Adjust torque at  $34 \pm 2\text{Nm}$ . Prevent the connector rotating when tightening. Cover the connector head on all parts with Petroleum Jelly or Swift 500 H paste. Put "o" rings K27 into the slots of lids. Press the lid into the connector head vertically from above, applying pressure. Fit lid GD 152 with the small hole for positive post and lid GD 153 with the big hole for negative. Clean excess Jelly / Paste from the top of the connector and lid.

### To disconnect the Connector

For disconnection, the first step is to remove the lids by means of a lever or screwdriver. In order to avoid any damage of the connector heads, the tool will be used through the lid hole. For connecting again all lids have to be exchanged with new ones. "O" ring may be exchanged if damaged.

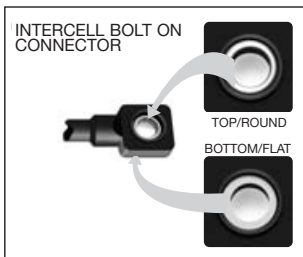
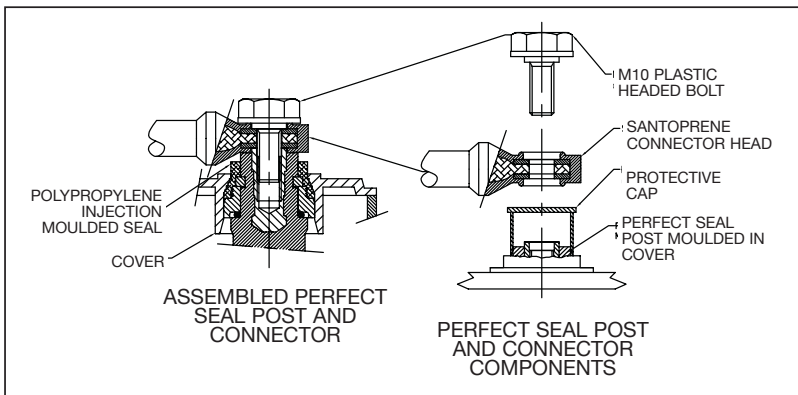

- Always ensure "curved" surface is uppermost when fitting connector
- Bottom "flat" surface must face bolt-on post

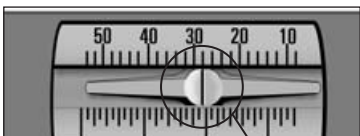



**28Nm**

It is **imperative that a torque of  $28\text{Nm} \pm 1\text{Nm}$**  is applied when fitting Euro connectors.

## MINING MOTIVE POWER CONNECTORS

| Positive Take-off  |        |
|--|--------|
|  |        |
| CODE   | LENGTH |
| CB345  | 1200mm |

| Negative Take-off  |        |
|--|--------|
|  |        |
| CODE   | LENGTH |
| CB450  | 4800mm |

| Euro connection   |        |
|---|--------|
|  |        |
| CODE  | LENGTH |
| CB339   | 170mm  |
| CB340   | 190mm  |
| CB342   | 235mm  |
| CB344   | 250mm  |
| CB441   | 265mm  |
| CB443   | 385mm  |
| CB444   | 600mm  |

## SURFACE MOTIVE POWER CONNECTORS

| BS BOLT ON CONNECTORS CATALOG NUMBER |                  |                    |                   |                   |                   |
|--------------------------------------|------------------|--------------------|-------------------|-------------------|-------------------|
| CELL TYPE                            | LENGTH<br>'A' mm | CROSS SECTION AREA |                   |                   |                   |
|                                      |                  | 35mm <sup>2</sup>  | 50mm <sup>2</sup> | 70mm <sup>2</sup> | 95mm <sup>2</sup> |
| 5 PLATE F-F                          |                  |                    |                   |                   |                   |
| 7 PLATE F-F                          | 75 ±1.5          | CB 337             | CB 303            |                   |                   |
| 9 PLATE F-F                          | 95 ±1.5          | CB 299             | CB 316            |                   |                   |
| 11 PLATE F-F                         | 105 ±2.0         | CB 300             | CB 317            |                   |                   |
| 13 PLATE F-F                         | 125 ±2.0         | CB 297             | CB 314            |                   |                   |
| 15 PLATE F-F                         | 140 ±2.0         | CB 304             | CB 326            | CB 319            |                   |
| 17 PLATE F-F                         | 155 ±2.0         | CB 302             | CB 395            | CB 321            |                   |
| 19 PLATE F-F                         | 170 ±2.0         | CB 305             | CB 323            | CB 339            |                   |
| 21 PLATE F-F                         | 190 ±2.0         | CB 306             | CB 324            | CB 340            |                   |
| 23 PLATE F-F                         | 205 ±3.0         | CB 307             | CB 325            | CB 341            | CB 352            |
| 25 PLATE F-F                         | 220 ±3.0         | CB 309             | CB 327            | CB 343            | CB 354            |
| 27 PLATE F-F                         | 235 ±3.0         | CB 308             | CB 394            | CB 342            | CB 353            |
| 29 PLATE F-F                         | 250 ±3.0         | CB 310             | CB 328            | CB 344            | CB 355            |
| E-E 5-15 PLATE                       | 90 ±1.5          | CB 298             | CB 315            | CB 333            |                   |
| E-E 17-29 PLATE                      | 95 ±1.5          | CB 299             | CB 316            | CB 334            | CB 349            |

|          | BS CONNECTOR CROSS SECTION AREA mm <sup>2</sup> |      |      |      |      |      |
|----------|---|------|------|------|------|------|
|          | BIKR  | BIMF | BILF | BTLF | BTHF | BTEF |
| 5 PLATE  | 35  | 35   | 35   | 35   | 35   | 35   |
| 7 PLATE  | 35  | 35   | 35   | 35   | 35   | 35   |
| 9 PLATE  | 35  | 35   | 35   | 35   | 35   | 50   |
| 11 PLATE | 35  | 35   | 35   | 35   | 50   | 50   |
| 13 PLATE | 35  | 35   | 35   | 50   | 50   | 50   |
| 15 PLATE | 35  | 35   | 50   | 50   | 50   | 70   |
| 17 PLATE | 35  | 35   | 50   | 50   | 50   | 70   |
| 19 PLATE | 35  | 50   | 50   | 50   | 70   | 70   |
| 21 PLATE | 35  | 50   | 50   | 70   | 70   | 70   |
| 23 PLATE | 35  | 50   | 50   | 70   | 70   | 95   |
| 25 PLATE | 35  | 50   | 70   | 70   | 70   | 95   |
| 27 PLATE | 35  | 50   | 70   | 70   | 70   | 95   |
| 29 PLATE | 35  | 50   | 70   | 70   | 95   | 95   |

| DIN BOLT ON CONNECTORS CATALOG NUMBER |                  |                    |                   |                   |                   |
|---------------------------------------|------------------|--------------------|-------------------|-------------------|-------------------|
| CELL TYPE                             | LENGTH<br>'A' mm | CROSS SECTION AREA |                   |                   |                   |
|                                       |                  | 35mm <sup>2</sup>  | 50mm <sup>2</sup> | 70mm <sup>2</sup> | 95mm <sup>2</sup> |
| 5 PLATE F-F                           |                  |                    |                   |                   |                   |
| 7 PLATE F-F                           | 80 ±1.5          | CB 296             | CB 313            |                   |                   |
| 9 PLATE F-F                           | 95 ±1.5          | CB 299             | CB 316            |                   |                   |
| 11 PLATE F-F                          | 115 ±2.0         | CB 301             | CB 318            | CB 335            |                   |
| 13 PLATE F-F                          | 140 ±2.0         |                    | CB 326            | CB 319            |                   |
| 15 PLATE F-F                          | 155 ±2.0         |                    | CB 395            | CB 321            |                   |
| 17 PLATE F-F                          | 170 ±2.0         |                    | CB 323            | CB 339            | CB 350            |
| 19 PLATE F-F                          | 190 ±2.0         |                    | CB 324            | CB 340            | CB 351            |
| 21 PLATE F-F                          | 205 ±3.0         |                    | CB 325            | CB 341            | CB 352            |
| 5-21 PLATE E-E                        | 105 ±1.5         | CB 300             | CB 317            | CB 392            | CB 393            |
| *BRIDGING<br>CONNECTOR                | 310 ±3.0         | CB 360             | CB 361            | CB 362            | CB 363            |

\* Applicable to 48V circuit B battery layout

| DIN CONNECTOR CROSS SECTION AREA mm <sup>2</sup> |      |      |      |       |      |      |        |
|--|------|------|------|-------|------|------|--------|
|  | DWAF | DWBF | DWCF | LDWEF | DWEF | DWFF | DWFF-H |
| 5 PLATE  | 35   | 35   | 35   | 35    | 35   | 35   | 35     |
| 7 PLATE  | 35   | 35   | 35   | 35    | 35   | 50   | 50     |
| 9 PLATE  | 35   | 35   | 50   | 50    | 50   | 50   | 50     |
| 11 PLATE   | 35   | 50   | 50   | 50    | 50   | 70   | 70     |
| 13 PLATE   | 50   | 50   | 50   | 70    | 70   | 70   | 70     |
| 15 PLATE   | 50   | 50   | 70   | 70    | 70   | 70   | 70     |
| 17 PLATE   | 50   | 70   | 70   | 70    | 70   | 95   | 95     |
| 19 PLATE   | 50   | 70   | 70   | 95    | 95   | 95   | 95     |
| 21 PLATE   | 50   | 70   | 70   | 95    | 95   | 95   | 95     |

| BS AND DIN TAKE OFF CONNECTORS CATALOG NUMBER |                        |                    |                   |                   |                   |
|---|------------------------|--------------------|-------------------|-------------------|-------------------|
| APPLICATION                                   | CABLE LENGTH<br>'B' mm | CROSS SECTION AREA |                   |                   |                   |
|   |                        | 35mm <sup>2</sup>  | 50mm <sup>2</sup> | 70mm <sup>2</sup> | 95mm <sup>2</sup> |
| TAKE OFF                                      | 1200 ±5                | CB 312             | CB 330            | CB 345            | CB 356            |
| TAKE OFF                                      | 1500 ±5                | CB 359             | CB 331            | CB 346            | CB 357            |
| TAKE OFF                                      | 500 ±5                 | CB 402             | CB 403            | CB 404            | CB 405            |

## INTERCELL CONNECTORS

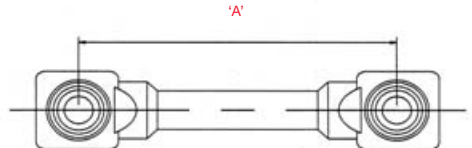
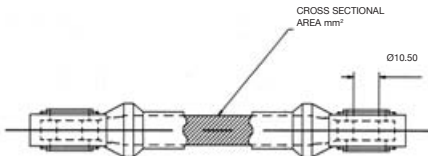

## DIN AND BS TAKE-OFF CONNECTORS

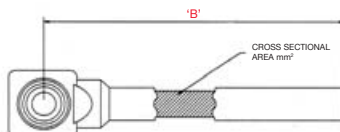

## BOLT-ON® CONNECTORS

### Torque bolts regularly.

#### Excess Torque could:

- Damage plastic bolt
- Break cell post
- Fracture group bar

#### Under Torque could:

- Result in connection becoming loose
- Poor connection could generate heat

**All of these faults can cause sparks and therefore a possible explosion**

# Specific Gravity Measurement

## DETERMINING THE STATE OF CHARGE OF THE BATTERY

Dilution of the electrolyte during discharge and re-concentration during charge is a useful guide to the state of charge of a lead acid cell. The less acid there is in the electrolyte, the less dense it is, and the lower its specific gravity (S.G.). One cubic centimetre of water has a mass of 1 gram. In other words, its density is 1 gram per  $\text{cm}^3$  at  $4^\circ\text{C}$ . Specific gravity is the ratio of the density of the substance measured to the density of water. Density of water at  $4^\circ\text{C}$  =  $1.000 \text{ g/cm}^3$ . The specific gravity of water is therefore usually expressed as 1.000.

Density could also be expressed as the mass of the liquid divided by the mass of an equal volume of water.

Specific gravities are usually measured with a hydrometer. This works on the principle that a float will sink further into a liquid of low specific gravity than of high specific gravity because the latter is denser and provides greater support.

## USING THE HYDROMETER

From one of the cells, draw acid into the barrel until the hydrometer float moves freely. Now read the specific gravity at the point where the scale emerges from the acid. Afterwards, make sure the acid is returned to the cell from which it was drawn, or the specific gravity and acid level of both cells will be altered. **Illustration 3.**

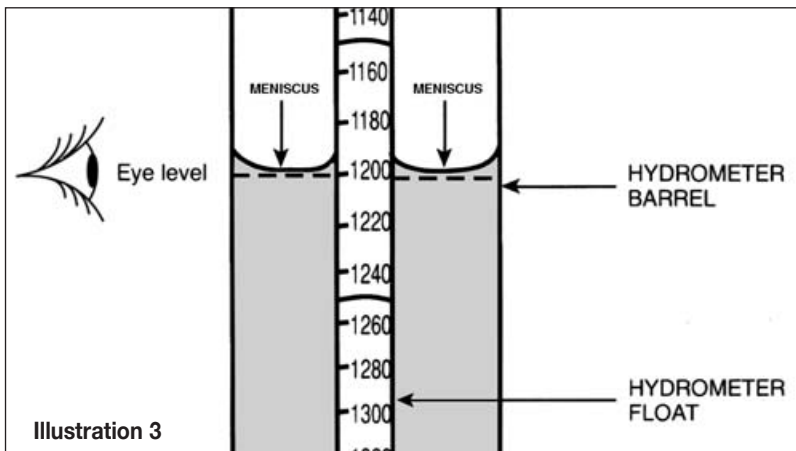

When taking a reading

- Make sure that there are no air bubbles under the float.
- Bring your eye level with the acid surface in the barrel of the hydrometer.
- Ensure that the hydrometer is in a vertical position.
- If necessary, shake the hydrometer gently to enable the float to move freely.
- If the ambient temperature differs from the battery temperature, draw in electrolyte to warm the hydrometer first.
- Read off against the lower meniscus.

Wash the hydrometer barrel and float with soap and water on a weekly basis. Rinse thoroughly with water after washing to prevent soap transfer to the battery electrolyte.

The change in specific gravity of the acid is directly proportional to the ampere hours taken out of the cell on discharge.

Where extreme accuracy is required, a reading should be taken after a stabilisation period of several hours with the battery on open circuit. The minimum recommended specific gravity is 1.140. Select a different pilot cell each month to serve as a useful, general indicator of the condition of the battery during charge and discharge.

**Note:** The specific gravity of a cell will decrease with any increase in temperature.

Always record the electrolyte temperature when specific gravity readings are taken.

Cells should not as a rule be discharged more than 80% of their nominal capacity.

## TEMPERATURE CORRECTION

All specific gravities quoted relate to temperature at 25°C and have to be corrected if read at other electrolyte temperatures.

Specific gravities decrease as the temperature increases. To provide a standard, the specific gravity can be corrected to 25°C in the following manner:

Take the temperature of the electrolyte and

- add 7 points (0.007) to the specific gravity reading for every ten degrees above 25°C
- or
- subtract 7 points (0.007) from the specific gravity reading for every ten degrees below 25°C

For example:

A reading of 1.255 at 35°C corrected to 25°C gives  $1.255 + 0.007 = 1.262$

or

A reading of 1.275 at 15°C corrected to 25°C gives  $1.275 - 0.007 = 1.268$

## SPECIFIC GRAVITY WHEN FULLY CHARGED

With the electrolyte level correct, the fully charged specific gravity for new cells will be 1.260 - 1.270. During the first few weeks of service the specific gravity will rise and will typically stabilise between 1.290 - 1.300 for Surface Motive Power cells, and 1.270 - 1.280 for Mining Motive Power cells.

# Charging a Battery

To ensure maximum performance, both in terms of battery capacity and expected life, correct charging is essential.

Always open battery covers whilst charging to prevent accumulation of hydrogen, minimise corrosion and assist in cooling.

In general, a battery may be charged at any rate in amperes that will not produce excessive gassing or result in electrolyte temperatures above 45°C. A discharged battery can accept high rates of charge initially but, as the gassing stage is approached (2.39 volts per cell), the current must be reduced to avoid excessive gassing and high temperatures which can permanently damage the plates and separators.

A battery should always receive the 'correct' amount of charge - sufficient to fully charge it and/or maintain it in that condition, but no more. In other words, **undercharging** or **overcharging** should be avoided to the extent that it is practical under conditions of usage.

An insufficient charge, even to the smallest degree but continuously, will cause gradual sulphation of the plates, with eventual loss of capacity and a reduction of battery life.

Excessive charging will tend to corrode, the positive spines, forming lead dioxide, weakening them physically and increasing their electrical resistance. If overcharging is at comparatively high rates, gassing will also be excessive and this tends to "wash" the active material from the plates. In addition the operating temperatures will probably increase to unacceptable levels. All of these factors reduce the capacity and shorten the life of the battery.

With any type of battery operation there are reasonably simple checks to determine whether or not the amount of charge is correct. If the proper amount of charging is being given, the specific gravity will reach its fully charged value at the end of recharge and will remain at that value. In addition, the amount of water required by the cells each cycle will be minimal.

If the specific gravity does not reach the fully charged value and/or tends to show a continuing decline it is evident that the battery is not receiving sufficient charge.

On the other hand, if the specific gravity reaches or remains at full charge level and an excessive amount of water is required, the battery is receiving an excessive charge and the rate should be reduced.

To keep the battery in good condition it is necessary to use a charging regime that takes into consideration the operational function of the battery.

To provide the correct charge regime the current and voltage of the charger must be correctly adjusted and the duration of the different charging stages carefully monitored. Volt and ammeters should be calibrated at regular (six-to-twelve monthly) intervals.

## **BATTERY CHARGERS: BASIC PRINCIPLES**

There are three types of traction chargers commonly in use and although types may differ, the principles remain the same.

Each of these three types is available as either eight-hour or twelve-hour chargers, depending on the user's requirements.

## TAPER CHARGERS (TYPICALLY 12 HR) Illustration 4

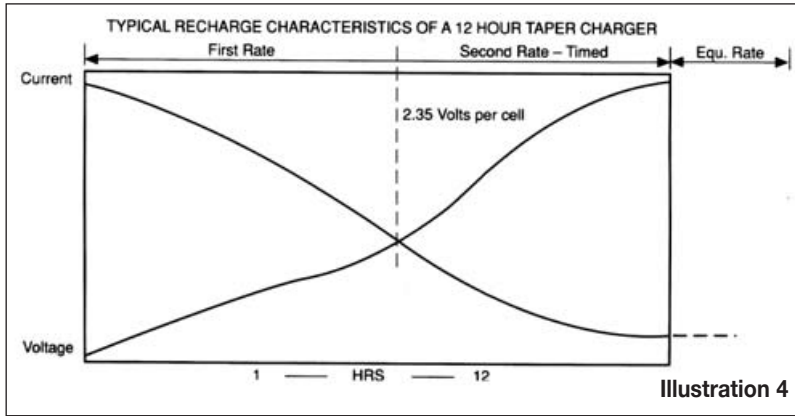

These are normally used on surface motive power batteries and can be either air or oil cooled. As illustrated below the current in a taper charger falls (or tapers) as the charge proceeds and the battery voltage rises.

The charge starts at the 'first rate' for an undefined period until 2.35 volts per cell is reached. For this period the starting current should be:

$$\frac{\text{Battery Ampere hours (Ah)}}{7.2} = \text{Amperes}$$

The charger control senses the cell voltage and at 2.35 volts per cell activates the 'second rate' usually for a period of 3-4 hours after which the unit switches off. Battery manufacturers normally specify the maximum charge current at 2.5 volts per cell as follows:

$$\frac{\text{Battery Ah}}{12} = \text{Amperes}$$

Many taper chargers have an automatic equalize facility, but sometimes the equalize charge is set manually by a switch. Equalize charging current should be

$$\frac{\text{Battery Ah}}{30} = \text{Amperes}$$

It usually takes about 12 hours for a taper charger to charge a fully discharged battery.

### WARNING

The taper charger is highly susceptible to mains voltage fluctuation. A 10% increase in voltage input can result in up to 45% increase in output current. Where the voltage supply is not stable the taper charger is not recommended.

**CONSTANT CURRENT CHARGERS (TYPICALLY 8 HR) Illustration 5**

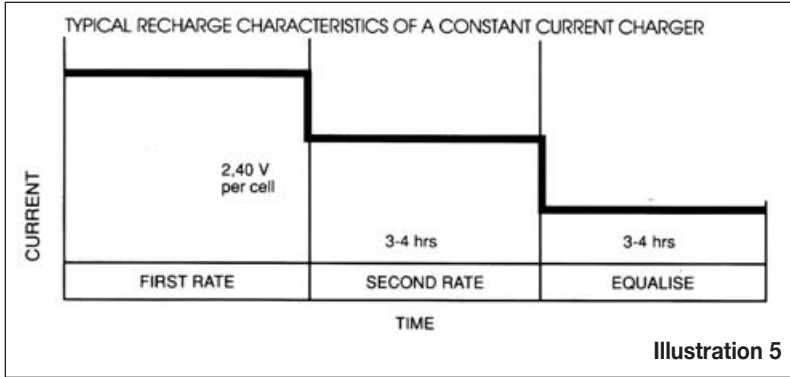

The principle of constant current charging, the three current rates being represented as straight lines, ie constant current.

The first rate charge is continuous until 2.4 volts per cell is reached. This current rate should be

$$\frac{\text{Battery Ah}}{5} = \text{Amperes}$$

As with the taper charger the charger control senses 2.4 volts and activates the 'second rate' for a period of 3 to 4 hours, at a constant current rate of

$$\frac{\text{Battery Ah}}{15} = \text{Amperes}$$

At the end of this period the unit usually switches automatically to 'equalize rate' and continues to charge at

$$\frac{\text{Battery Ah}}{30} = \text{Amperes}$$

for 3 or 4 hours before automatically switching off. The equalise rate may be in the form of pulse charging (i.e. when the battery voltage drops to a predetermined level the charge is applied for a few minutes and then is switched off until the voltage again drops to the predetermined level).

## MODIFIED CONSTANT CURRENT/TAPER CHARGER (TYPICALLY 12 HR) Illustration 6

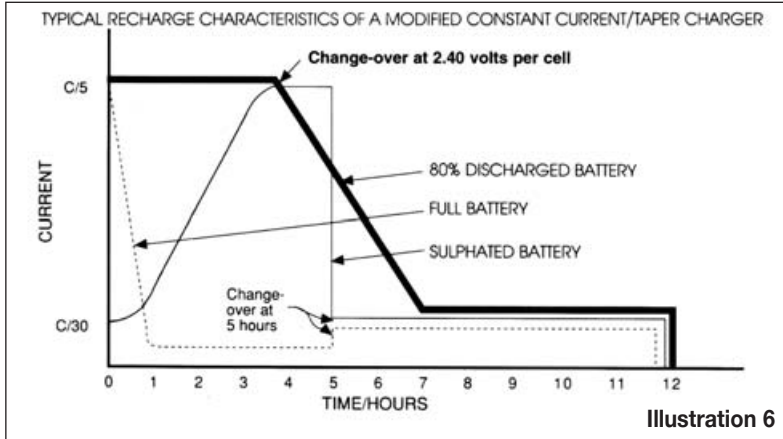

This charger uses a first rate of constant current of

$$\frac{\text{Battery Ah}}{5} = \text{Amperes}$$

until the battery reaches a voltage of 2.40 volts per cell. After this stage the charger switches to a second rate taper charge mode, with the battery voltage rising to approximately 2.44 volts per cell, allowing the current to taper down. This taper rate depends on battery discharge and age. The taper rate is fixed by the charger timer for a 5 hour period after which the control unit switches to the equalizing mode at

$$\frac{\text{Battery Ah}}{30} = \text{Amperes}$$

This rate will continue until the overall charging time has reached 12 hours. On a new battery under equalizing charge the voltage will rise to approximately 2.6 to 2.7 volts per cell.

### CHARGE CYCLE OF AN 80% DISCHARGED BATTERY

(Note: Time 6 1/2 hours to total recharge and an acceptable temperature rise of 20°C)

### CHARGE CYCLE OF A FULLY CHARGED BATTERY

(Note: The charger immediately enters second rate and tapers down to battery current requirements)

### CHARGE CYCLE OF A SULPHATED BATTERY

Where cells are so severely over-discharged that they have a high internal resistance due to sulphation, the charger control could interpret the resistive voltage drop as cell voltage, switch to second rate and under-charge the battery.

As shown in the graph ("Sulphated battery") the elevated voltage in the second rate will allow the current to climb as the sulphation is broken down and repeated charges could ultimately recover the battery.

**Illustration 6.**

## **AUTOMATIC TIMER RELAYS**

These devices work on the principle of a voltage sensing relay sensing the predetermined set voltage of the battery being charged. This starts a timing mechanism which, after the preset period, terminates charging.

Most of these devices have L.E.D. indication for charge conditions showing first rate, second rate, equalizing rate and charge complete.

## **DV/DT TERMINATION OF CHARGE**

Modern constant current chargers may monitor the battery voltage to determine when the voltage stabilises or starts to go down. At this point the battery is deemed to be fully charged and the charge is terminated.

## **EQUALIZING CHARGES**

All cells in a battery have slightly different characteristics. This means, in effect, that the amount of charge required is different for each cell. This is accentuated after very deep discharges and may be observed by small variations in the value of voltage and specific gravity readings between each cell after charging has been completed.

If the variation is allowed to continue, the differences may be further accentuated and the effective working life of the battery may be reduced. To avoid this, an equalizing charge is recommended. This is an extended charge which should be given at least once a week.

Most chargers have an automatic switch which selects the special rate for an equalizing charge. Such a charge is complete when the voltage and specific gravities of the cells have remained constant over three successive hourly readings.

# **Battery Maintenance**

A lead acid motive power battery requires very little maintenance, but attention to the following points will ensure that the battery gives maximum performance and remains in service longer.

## **EQUIPMENT CHECKS**

- the charger is giving the rated output and matches the battery capacity.
- the voltage relay operates at 2.35 volts per cell for a taper charger and at 2.40 volts per cell for a two rate charger.
- the timer period between the voltage relay operating and the end of charge is set correctly.

## **UNDERCHARGING**

Undercharging over a period of time is one of the most destructive forms of abuse to which a battery can be subjected. The formation of excessive amounts of lead sulphate cause the positive plates to expand and break up while the negative active material hardens and loses capacity. The best protection against under-charging is a regular check on the specific gravity readings of the battery after the normal recharge has been completed.

If readings show consistent undercharging, remedial action must be taken.

## **OVERCHARGING**

Overcharging is another form of abuse which can have a serious effect on battery life, although its effects are not as immediately obvious as those of undercharging. It is, therefore, important to check battery voltage and charge current from the charger's ammeter, and compare it with the recommended rate.

Overcharging due to excessively high charging rates or charging for too long a period produces excess gassing, high temperatures and corrosion of the positive spine. These all result in shedding of active materials and greater water loss.

## **OVERDISCHARGING**

A battery should not normally be discharged more than 80% of its capacity. The specific gravity of the electrolyte is a fairly accurate reflection of the ampere hours that have been taken from a cell on discharge. The battery is 80% discharged when the specific gravity is 1.140.

If undercharging is combined with over-discharging the effects are intensified. Strictly speaking, a battery is not overdischarged at any rate unless more than its capacity at that rate has been taken out. Nevertheless, it is highly undesirable to take out anything approaching 100% of its rated capacity on a regular basis.

**A BATTERY SHOULD NOT NORMALLY BE DISCHARGED MORE THAN 80% OF ITS CAPACITY.** If the battery is grossly overdischarged the temperature will rise dramatically in the latter stages. The battery should be allowed to cool before recharge.

## **NEVER REMOVE A BATTERY FROM THE CHARGER WHILE THE BATTERY RELAY IS STILL IN OPERATION**

A charger operates according to a fixed programme and interrupting the charge will result in a over or under-charging of the battery.

Take weekly readings of a pilot cell immediately after completion of work when the specific gravity will be at its lowest. If the specific gravity falls below 1.140 the battery is either being over discharged or there is a failure in the battery and appropriate action should be taken.

Once weekly take specific gravity of the pilot cell before commencing work. If the specific gravity is below 1.280 the battery is being undercharged or there is a fault in the battery and corrective action should be taken.

Once per month record top of charge readings of specific gravity of each cell. If the specific gravities (with correct electrolyte levels) are above 1.300, adjust the gravity to within the range 1.290 / 1.300 by removing some electrolyte and replacing with approved water. If necessary contact your local First National Battery branch for assistance.

Should any difficulty be experienced in giving batteries the right amount of charge, a First National Battery service technician should be called in to inspect the battery and charger installation.

## **ENSURE CELLS ARE CORRECTLY TOPPED UP**

Keep a stock of topping up water, in a clean non-metallic container provided with a stopper to prevent the entry of dirt or other contaminants.

Keep any metal object well away from the cell top when topping up, to avoid the risk of a short-circuit through contact with the connectors.

Top up at regular intervals, once a week is ideal even though it may be found at times that only a small quantity of water is needed. The frequency of this routine will depend very much on operating conditions, but the routine should be strictly adhered to.

Low electrolyte levels will cause oxidation of the plates and high battery temperature on charge. High electrolyte levels from overtopping will cause the electrolyte to flood the tops of the cells during gassing on charge with a resultant loss of electrolyte.

The electrolyte level should always be kept just above the separator guard, but never more than 20 mm above it. If spillage of electrolyte occurs, contact your local First National Battery branch for assistance.

The correct time to top up is when the battery is about 80% through a charge. Avoid topping up batteries directly after discharge.

### **NEVER ADD ACID OR ANY 'SPECIAL SOLUTIONS' TO CELLS**

All cells in a battery should require roughly the same amount of water. If individual cells are found to need appreciably more or less than others, this should be investigated and reported to the service engineer.

Only distilled water, deionized water or other approved water should be used for topping up. Casual indiscriminate use of any available water may cause premature battery collapse and will nullify the warranty. If there is any doubt about the suitability of the water supply, submit a sample in a clean stoppered bottle, together with details of the source of supply to First National Battery. From this an analysis will be made and a report submitted.

Keep filler vent plugs and connections tight. Remove filler plugs only when topping up or taking specific gravity readings.

Prevent any form of foreign matter entering cells.

Under normal operating conditions only water is lost from the cells through the natural evaporation and electrolysis caused by gassing during charge. **It is this water which is replaced during topping up and NOT the acid.**

Check that the shrouds are fitted to the inter-cell connectors correctly and that they are not damaged. Any damaged shrouds should be replaced immediately.

Prevent any form of foreign matter entering cells.

### **NEVER USE A NAKED FLAME NEAR A BATTERY**

Gases given off by a battery are explosive, particularly during charge or shortly after.

### **KEEP CELLS, TRAYS AND CONTAINERS DRY AND CLEAN**

Corrosion and any products of corrosion should be removed and acid neutralised with a solution of 1 kg bicarbonate of soda to 10 litres of water. Another effective acid neutralising agent is dilute ammonia (dilution strength one part ammonia to three parts water). Avoid the solution entering the cells.

Further corrosion can be avoided by covering the affected area with an acid proof paint or swift 500H paste.

Trays should occasionally be washed down with one of these solutions and coated with acid proof paint once they are dry.

When a battery top is wet, current will track between the terminals, causing not only a loss of capacity on open circuit but also corrosion of the terminals.

Small amounts of acid deposited onto cell tops during charging can cause the battery box to deteriorate. Any spillage should be wiped away immediately.

Ensure vent cap holes are not obstructed, by cleaning regularly.

## COVER ALL EXPOSED METAL LIGHTLY WITH SWIFT 500H PASTE

This will help to prevent corrosion and the short circuiting caused by the effects of acid spillage.

# General Information

## FIELD PROBLEMS

Records maintained regularly are often invaluable in determining potential problems. The following conditions serve as symptoms of trouble that might occur in future:

- **Irregular specific gravity** (a spread of 40 or more points) may be caused by:
  - a leaking jar or container
  - overtopping
  - an internal short circuit
  - an inadequate charge
- **Excessive water** requirement:
  - by the battery as a whole - indicates probable excessive charging:
  - by individual cell(s) - probably means jar leakage.
- **Lower than average water requirement** by a cell(s), accompanied by lack of normal gassing indicates a need for a thorough equalizing charge or possible internal trouble.
- **Overheating** of the battery as a whole is usually the result of charging at excessive current rates, overcharging, over-discharging or lack of adequate ventilation.
- **Heating of an individual cell** indicates internal trouble. When the cause is not readily discerned, give the battery a thorough equalizing charge (except for cases of excessive water use or overheating). If this remedies the condition, continue to operate normally but recheck later to ensure that the trouble does not recur. If the cause cannot be determined, consult a First National Battery service technician.

## BATTERY CAPACITY

A battery's capacity will decrease toward the end of its life. Unless a specific problem occurs, this will be a gradual decrease and ample warning of reduced capacity will be evidenced by the slowing down of the vehicle toward the end of the day's work.

A battery is considered to be at the end of its useful life when its capacity decreases below 80% of its rating. However, it can sometimes be transferred to a smaller job to provide additional life and service. As a motive power battery usually discharges every day in the course of its regular performance, it is seldom necessary to conduct a formal test of its capacity. Most users do not have the facilities to do this conveniently or accurately. If any such testing is desired, consult the First National Battery service technician.

## HIGH TEMPERATURE OPERATION

While the capacity of a battery is increased somewhat at higher temperatures, heat also has other adverse effects and all practical means should be employed to keep the battery temperature normal.

Higher temperatures also increase the charging current and may result in a considerable overcharge. This means increased water usage, greater 'formation' (corrosion) of the positive plate spines and a shorter battery life.

Any tendency for battery temperatures to rise above 45°C due to operating conditions, should be minimised by:

- avoiding over-discharge
- charging in a cool location
- supplying ample ventilation during charge by opening the battery compartment and circulating air by fans if necessary.

**Note:** For every 10°C rise in average battery temperature, the service life of lead acid batteries is reduced by approximately 50%.

## **COLD STORE OPERATION OF MOTIVE POWER BATTERIES**

### **Electrolyte temperature affect on capacity**

As electrolyte temperature drops the amount of capacity available is reduced. The rate of loss increases as the temperature decreases. Thus, a drop from nominal operating temperature of 30°C to 0°C will reduce available capacity to 83%. A further drop in temperature to minus 30°C will reduce capacity to 35%.

### **Typical figures**

Whilst a number of factors may affect the battery capacity, an average size battery starting an eight-hour shift with a newly fully charged battery at 35°C in a cold room at 0°C will finish the shift at about 13°C. The available capacity at this temperature is 96% of nominal. Similarly, operating in a cold room at minus 30°C would result in the battery being at about 0°C. Available capacity at this temperature would be 80%.

### **Minimising capacity loss**

The following steps should ensure that the reduction in available capacity is restricted to less than 15%.

- a) Charge the battery outside the cold room in normal ambient conditions.
- b) Use an eight-hour charger.
- c) Ensure battery lid is a good fit.
- d) Line the lid with insulating material (e.g. expanded Polystyrene)
- e) Always remove the machine from the cold room at break times and whenever there is a period that it is going to stand idle.

### **Warning**

Never leave the battery standing in the cold room for long periods when not in use. Whilst in operation the temperature / capacity relationship will ensure that freezing cannot occur but, the temperature of a discharged battery that is left standing may fall below the electrolyte freezing point.

## **ELECTROLYTE AGITATION (OPTIONAL)**

Advantages:

- less gassing reduced water loss during the charging cycle.
- charging time is reduced, reducing energy input.
- temperatures during charging are lower, thus extending battery life.
- charge acceptance is maximised.
- reduced maintenance.

## STORAGE OF BATTERIES

Batteries should be stored in a clean, cool, dry and well ventilated location away from radiators, heating ducts or other sources of heat and protected from exposure to direct sunlight.

Before storing, it is necessary that the battery be fully charged and the electrolyte at the proper level. Disconnect leads or cable connections to prevent use or possible discharge through tracking during prolonged storage. Do not remove the electrolyte or strip out the cells.

If the storage temperature is 25°C or higher, check the specific gravity at least once a month. If it is below 25°C, every second month. Whenever the specific gravity falls to about 1.230 or lower, give a freshening charge. Always give a freshening charge prior to returning to service.

## BATTERY WATER

Water used for topping up batteries must comply with the following specifications:

- It shall be clear, colourless and odourless.
- The pH shall be between 5 and 7.
- Impurities shall not exceed the limits below.
- It shall, wherever possible, be stored in a glass or plastic container.
- Conductivity shall be less than 30 µS/cm

| Impurities                              | Milligrams per litre |
|---|----------------------|
| Dissolved solids                        | 25                   |
| Arsenic (As)                            | 1                    |
| Chloride (Cl)                           | 5                    |
| Copper (Cu)                             | 0,1                  |
| Iron (Fe)                               | 0,2                  |
| Manganese (Mn)                          | 0,1                  |
| Nitrogen (as NH <sub>4</sub> )          | 5                    |
| Nitrogen (as NO <sub>3</sub> )          | 5                    |
| Heavy metals (as Pb)                    | 5                    |
| KMnO <sub>4</sub> reducing substances * | 10                   |

\*As determined by F.N.B. test method LTM - 31 - 01

**NB. Non-adherence to the above battery maintenance instructions nullifies the warranty.**

# Safety Rules

Highly-explosive hydrogen gas is produced while charging a battery. This gas remains in the cells long after charging has stopped. Do not smoke, use an open flame, create an arc or sparks in the vicinity of any battery. If the battery is in an enclosed space, ensure that it is well ventilated, particularly when charging.

All batteries contain sulphuric acid which may cause serious burns, so contact with eyes, skin or clothing should be avoided. Wear a face mask, plastic or rubber apron, gloves and boots. If some spillage occurs on the skin, rinse promptly with clear water and wash with soap. A solution of bicarbonate of soda (1 kg to 10 litres of water) will neutralise acid spilled on clothing or other material. Apply until bubbling stops and rinse with clear water. In case of contact with eyes, flush immediately and thoroughly with clean water and seek medical attention without delay.

Lead acid batteries are capable of high voltage and current which can shock personnel.

Do not lay any metallic object on the battery as it may cause a short circuit and an explosion.

Only remove vent plugs for cleaning, adding water or taking hydrometer readings. Keep them firmly in place at all other times.

Do not permit any dirt, cleaning solution or other foreign material to enter the cell.

Torque bolts regularly.

Open covers during charge.

1. Proper personal protective equipment (PPE) is to be used when handling leaking batteries or electrolytes. PPE should include neoprene, rubber or latex-nitrile protective gloves, chemical resistant apron and eye protection. Persons handling batteries should not wear contact lenses and all tools must have insulated handles to prevent short circuits.
2. Do not smoke, have open flames, or make sparks around lead-acid batteries since a gassing battery can explode.
3. Personnel to be trained in battery maintenance procedures, first aid, use of protective equipment and hazards of battery maintenance operations.

All relevant SABS symbols to be explained and adhered to at all times.



- Observe the instructions for use.



- When working on batteries, wear safety glasses and protective clothing.



- No smoking. Do not allow naked flames, hot objects or sparks near the battery due to the risk of explosion or fire.



- Flush splashes of acid out of the eyes or off the skin with copious amounts of clean water, seek a doctor without delay. Clothing contaminated by acid should be washed out in water.



- Risk of explosion and fire - avoid short circuits.



- Electrolyte is highly corrosive.



- Old batteries must be returned for recycling.



- Keep away from children.

Batteries can be returned to any First National Battery branch or Battery Centre.

## **Motive Power Battery : Sole and Exclusive Warranty**

All batteries manufactured by FIRST NATIONAL BATTERY, a Division of METINDUSTRIAL (PTY) LTD (FNB) are guaranteed against faulty workmanship and defective materials, with effect from the date of delivery, for either a period of 1248 cycles of charge and discharge or a maximum period of 4 (FOUR) years - whichever occurs first.

This warranty is based on an average monthly usage of 26 cycles of charge and discharge (to a maximum of 80 percent of discharge of the cell's five-hour rated capacity). A cell will be deemed to have failed when it can no longer deliver 80 percent of its nominal five-hour capacity.

In the event of failure of the battery arising due to faulty workmanship or defective materials during the first 312 cycles or 1 (one) year, whichever occurs first, the battery will, at FNB's sole discretion, be replaced or repaired free of charge. Thereafter and during the remainder of the warranty term any replacement or repairs to battery by FNB will be performed on a *pro rata* basis (e.g. should a cell fail after 3 years - 36 months - (or 936 cycles) the cost to the customer for repair or replacement of the cell will be limited to 36/48 of FNB's then current list price).

This warranty on the replaced or repaired battery shall be limited to the remainder of the warranty term and subject to the terms and conditions herein.

This warranty will be rendered null and void should:-

- **the battery be used outside of the parameters contained in this warranty**
- **the battery not be operated and maintained in accordance with FNB's maintenance instructions**
- **the battery be topped up with any additives other than approved battery water**
- **the rated battery capacity be insufficient for, or in excess of the duty cycle required**
- **the battery be neglected, improperly used or abused in any way whatsoever whether internally or externally**
- **the equipment used to charge the battery be unsuitable or incorrectly adjusted for the battery being charged**
- **in the case of excessive/abnormal wear and tear**
- **damage be caused by repairs performed by a non-authorized party**

**FNB and its duly appointed agents exclude all liability whatsoever for any and all damaged, losses, injury or expenses and whether of a direct, indirect, incidental or consequential nature or otherwise and howsoever caused and by whomsoever suffered and which may arise out of or relate to the use or inability to use the battery or any failure whatsoever to meet this warranty.**

**This warranty is the only warranty which is given and is specifically in lieu of all other warranties, expressed or implied in law, including any implied warranty of fitness for a particular purpose.**

**This warranty shall not prejudice any other rights that FNB may have in terms of the common law or these terms and conditions.**

**FIRST NATIONAL BATTERY DIVISION OF METINDUSTRIAL (PTY) LTD**

Reg. No. 1949/031259/07

**FIRST NATIONAL BATTERY INDUSTRIAL (PTY) LTD**

Reg. No. 2002/020394/07

**BENONI**

Liverpool Road, Industrial Sites

P.O. Box 5015, Benoni South,  
1502, South Africa.

Tel: international +27 11 741 3600

Fax: international +27 11 421 2642

[fnbindustrial@battery.co.za](mailto:fnbindustrial@battery.co.za)

[marketing@battery.co.za](mailto:marketing@battery.co.za)

**EAST LONDON**

Settlers Way & Edison Road

Gately Township, East London

P.O. Box 182, East London,  
5200, South Africa

Tel: international +27 43 731 1111

Fax: international +27 43 731 2007

[manufacture@battery.co.za](mailto:manufacture@battery.co.za)

[www.fnbindustrial.co.za](http://www.fnbindustrial.co.za)

[www.battery.co.za](http://www.battery.co.za)

**Whilst every care has been taken in the compilation of this publication we cannot be held responsible for any possible omissions or errors which may occur. YOUR CO-OPERATION IS APPRECIATED. CALL TOLL FREE 0800 112 600**

In the interests of continuing advancement we reserve the right to modify specifications without notice.

© "Copyright subsists in this work. Any unauthorised reproduction, adaption and copying of this document is an act of copyright infringement and entitles FIRST NATIONAL BATTERY, DIVISION OF METINDUSTRIAL (PTY) LTD to take legal action (both civilly and criminally) against the infringer."